



ALC15 Product Guide

Twilight Switch

Overview

The ALC15 twilight switch will turn artificial lighting on when the ambient light falls below a preset level. The artificial lighting will then be turned off either when the ambient light exceeds the preset level (*auto off*) or after a preset time delay (*timed off*).

For example, in the *auto off* mode the ALC15 can be used to switch external security lights on at dusk and automatically switch them off again at dawn. In the *timed off* mode display or sign lighting can be set to turn on when it gets dark and stay on only for a set time period.

An integral 2 minute time delay prevents nuisance switching caused by, for example, car headlights or dark clouds.

The unit has a highly accurate adjustable photocell; a selectable time delay; adjustable switching differential and is mounted in a vandal resistant IP66 enclosure.

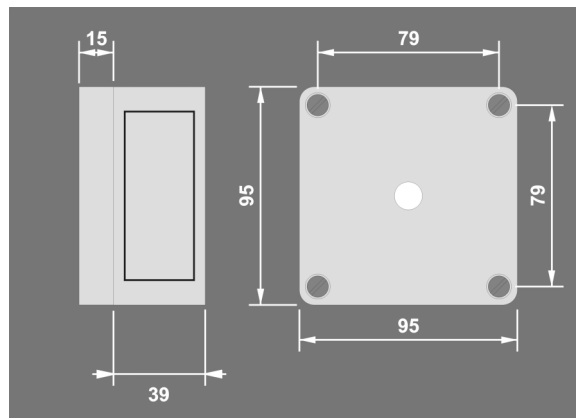

Wiring

Wire the ALC15 product as in the diagram.

The unit has a voltage free changeover output which can be used to switch, say, a BMS or lighting control system as well as switching a load directly. To switch a load directly link the *L* and *COM* terminals and take the output from the *NO* terminal.

- Where possible site the sensor as high as possible on a north facing vertical surface
- Avoid locating the ALC15 in direct sight of the light that it is controlling.
- Ensure that all cable entry to the enclosure is via suitable cable glands and seal with silicone sealant where appropriate.
- If it is necessary to screw through the rear of the enclosure ensure that any holes are covered with the caps provided and sealed with silicone sealant where appropriate.

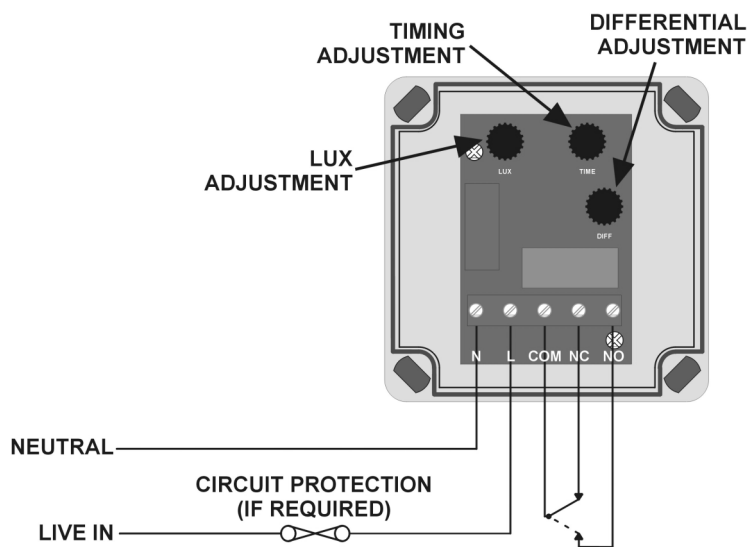

Installation

Warning. This device works at mains potential. Be sure to take care when working with electricity.

1. Make sure the load is connected and in working order.
2. Isolate the mains supply to the circuit at the main consumer unit.
3. Connect the controller via the terminal block. Live supply to the *L* terminal, Neutral to the *N* terminal.
4. For direct switching applications link *L* to *COM* and take the output from the *NO* terminal.
5. Set the *TIME* thumbwheel to *AUTO OFF* by turning fully anticlockwise
6. Set the *LUX* thumbwheel to *LATE* by turning fully clockwise.
7. Set the *DIFF* (differential) thumbwheel half way.
8. Power the unit up.
9. The lights will not come on until the ambient light level is very low.
10. Adjust the *LUX* level and differential using the guide overleaf.
11. Finally set the *TIME* thumbwheel to *AUTO OFF* or the desired time setting.

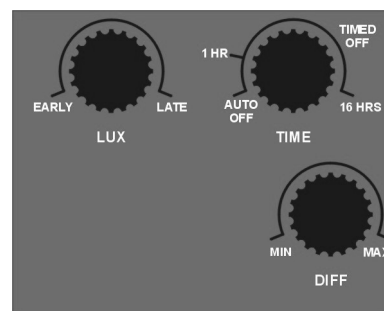

Thumbwheel settings

Installation cont.

ADJUSTING THE LUX LEVEL

1. The best time to set the LUX level is when the unit is just required to turn on.
2. Leave the *TIME* and *DIFF* thumbwheels set as above.
3. Turn the *LUX* thumbwheel **very slowly** anticlockwise towards the *EARLY* position until the lights come on.
4. There is a 2 minute time delay to prevent nuisance switching. This is **automatically disabled** whenever the *LUX* thumbwheel is turned, and then re-instated automatically after a further 2 minutes.
5. Turning the *LUX* thumbwheel to *EARLY* switches the unit earlier in the day, i.e. when ambient conditions are lighter. Turning to *LATE* switches the unit later in the day, i.e. when ambient conditions are darker.

ADJUSTING THE DIFFERENTIAL

1. After the unit has turned on, the differential is used to determine at what level of measured light to switch off again. It is only relevant in *AUTO OFF* mode.
2. If the differential is set to minimum the unit will turn off when the measured light is only a tiny bit greater than the level at which it turned on.
3. If the differential is set to maximum the unit will turn off then the measured light is much greater than the level at which it turned on.
4. If, say, the unit is set to turn on at dusk, set the differential lower (anticlockwise) if you want the lights to turn off again early in the morning and set the differential higher (clockwise) if you want the lights to turn off again when it is much lighter.
5. The differential is also useful if the unit can see the lights which it is controlling. In this case increasing the differential will prevent cycling of the output.

Fault Finding

LOAD DOES NOT COME ON

Remember there is a 2 minute delay to prevent nuisance tripping.

Check to see if the live supply to the circuit is good. Strap across the *L* and *LIVE OUT* terminal to turn the load on.

Try turning the *LUX* level to switch on earlier (anticlockwise).

LOAD DOES NOT GO OFF

If the unit is set to *TIMED OFF* it will not turn off until the time delay has finished.

Reduce the differential (*DIFF*) by turning anticlockwise.

LOAD CYCLES ON AND OFF

Increase the differential (*DIFF*) by turning clockwise.

Specification

LOAD

10 Amp incandescent lighting
6 Amp fluorescent lighting
3 Amp compact fluorescent lighting
3 Amp low energy lighting
3 Amp low voltage lighting (switch primary of transformer)
Fluorescent lighting (max 6 fittings recommended)
For fluorescent lighting total power factor correction capacitance must not exceed 40µF.
Switch SON lighting loads via a contactor

SUPPLY VOLTAGE 220-240 Volts AC 50 Hz
TIME OUT PERIOD Adjustable 1 hour to 16 hours or *AUTO OFF*.
LIGHT LEVEL Adjustment 10 LUX to 1000 LUX approximately.
TERMINAL CAPACITY 2.5mm²
IP RATING IP 66
MATERIAL Polystyrene
TYPE Class 2
TEMPERATURE -10°C to 35°C
CONFORMITY EMC-2004/108/EC
LVD-2006/95/EC



Part Numbers

ALC15 Twilight switch

IMPORTANT NOTICE!

This device should be installed by a qualified electrician in accordance with the latest edition of the IEE Wiring Regulations and any applicable Building Regulations.



C.P. Electronics Ltd

Brent Crescent
London
NW10 7XR
United Kingdom
Tel: + 44 (0) 333 900 0671
Fax: + 44 (0) 333 900 0674
www.green-iswitches.co.uk
enquiry@green-iswitches.co.uk